

MOC3010M MOC3011M MOC3012M MOC3020M MOC3021M MOC3022M MOC3023M

PACKAGE

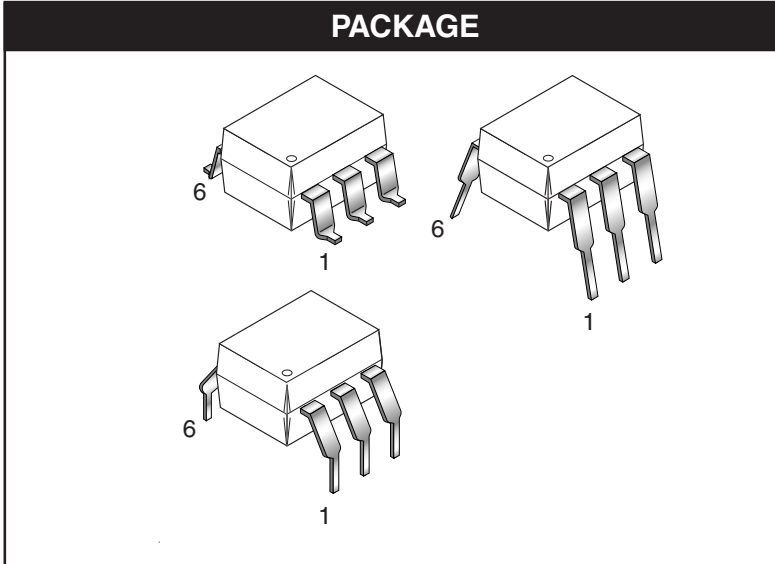

SCHEMATIC

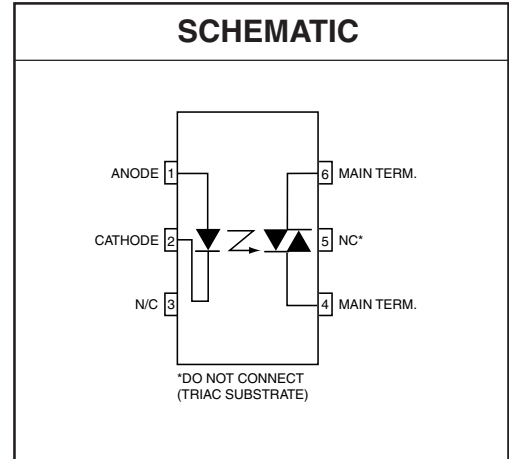

DESCRIPTION

The MOC301XM and MOC302XM series are optically isolated triac driver devices. These devices contain a GaAs infrared emitting diode and a light activated silicon bilateral switch, which functions like a triac. They are designed for interfacing between electronic controls and power triacs to control resistive and inductive loads for 115/240 VAC operations.

FEATURES

- Excellent I_{FT} stability—IR emitting diode has low degradation
- High isolation voltage—minimum 5300 VAC RMS
- Underwriters Laboratory (UL) recognized—File #E90700
- Peak blocking voltage
 - 250V-MOC301XM
 - 400V-MOC302XM
- VDE recognized (File #94766)
 - Ordering option V (e.g. MOC3023VM)

APPLICATIONS

- | | |
|-----------------------|-----------------------------|
| • Industrial controls | • Solenoid/valve controls |
| • Traffic lights | • Static AC power switch |
| • Vending machines | • Incandescent lamp dimmers |
| • Solid state relay | • Motor control |
| • Lamp ballasts | |

MOC3010M MOC3011M MOC3012M MOC3020M MOC3021M MOC3022M MOC3023M

ABSOLUTE MAXIMUM RATINGS ($T_A = 25^\circ\text{C}$ unless otherwise noted)				
Parameters	Symbol	Device	Value	Units
TOTAL DEVICE				
Storage Temperature	T_{STG}	All	-40 to +150	$^\circ\text{C}$
Operating Temperature	T_{OPR}	All	-40 to +85	$^\circ\text{C}$
Lead Solder Temperature	T_{SOL}	All	260 for 10 sec	$^\circ\text{C}$
Junction Temperature Range	T_J	All	-40 to +100	$^\circ\text{C}$
Isolation Surge Voltage ⁽¹⁾ (peak AC voltage, 60Hz, 1 sec duration)	V_{ISO}	All	7500	Vac(pk)
Total Device Power Dissipation @ 25 $^\circ\text{C}$ Derate above 25 $^\circ\text{C}$	P_D	All	330	mW
			4.4	mW/ $^\circ\text{C}$
EMITTER				
Continuous Forward Current	I_F	All	60	mA
Reverse Voltage	V_R	All	3	V
Total Power Dissipation 25 $^\circ\text{C}$ Ambient Derate above 25 $^\circ\text{C}$	P_D	All	100	mW
			1.33	mW/ $^\circ\text{C}$
DETECTOR				
Off-State Output Terminal Voltage	V_{DRM}	MOC3010M/1M/2M MOC3020M/1M/2M/3M	250 400	V
Peak Repetitive Surge Current (PW = 1 ms, 120 pps)	I_{TSM}	All	1	V
Total Power Dissipation @ 25 $^\circ\text{C}$ Ambient Derate above 25 $^\circ\text{C}$	P_D	All	300	mW
			4	mW/ $^\circ\text{C}$

Note

1. Isolation surge voltage, V_{ISO} , is an internal device dielectric breakdown rating. For this test, Pins 1 and 2 are common, and Pins 4, 5 and 6 are common.

MOC3010M MOC3011M MOC3012M MOC3020M MOC3021M MOC3022M MOC3023M

ELECTRICAL CHARACTERISTICS ($T_A = 25^\circ\text{C}$ Unless otherwise specified)

INDIVIDUAL COMPONENT CHARACTERISTICS

Parameters	Test Conditions	Symbol	Device	Min	Typ	Max	Units
EMITTER							
Input Forward Voltage	$I_F = 10\text{ mA}$	V_F	All		1.15	1.5	V
Reverse Leakage Current	$V_R = 3\text{ V}, T_A = 25^\circ\text{C}$	I_R	All		0.01	100	μA
DETECTOR							
Peak Blocking Current, Either Direction	Rated V_{DRM} , $I_F = 0$ (note 1)	I_{DRM}	All		10	100	nA
Peak On-State Voltage, Either Direction	$I_{TM} = 100\text{ mA peak}, I_F = 0$	V_{TM}	All		1.8	3	V

TRANSFER CHARACTERISTICS ($T_A = 25^\circ\text{C}$ Unless otherwise specified.)

DC Characteristics	Test Conditions	Symbol	Device	Min	Typ	Max	Units
LED Trigger Current	Voltage = 3V (note 3)	I_{FT}	MOC3020M			30	mA
			MOC3010M			15	
			MOC3021M				
			MOC3011M			10	
			MOC3022M				
			MOC3012M			5	
			MOC3023M				
Holding Current, Either Direction		I_H	All		100		μA

Note

1. Test voltage must be applied within dv/dt rating.
2. This is static dv/dt. See Figure 5 for test circuit. Commutating dv/dt is a function of the load-driving thyristor(s) only.
3. All devices are guaranteed to trigger at an I_F value less than or equal to max I_{FT} . Therefore, recommended operating I_F lies between max I_{FT} (30 mA for MOC3020M, 15 mA for MOC3010M and MOC3021M, 10 mA for MOC3011M and MOC3022M, 5 mA for MOC3012M and MOC3023M) and absolute max I_F (60 mA).

Fig. 1 LED Forward Voltage vs. Forward Current

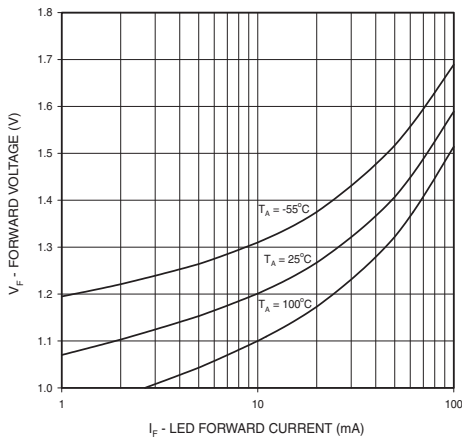

Fig. 2 On-State Characteristics

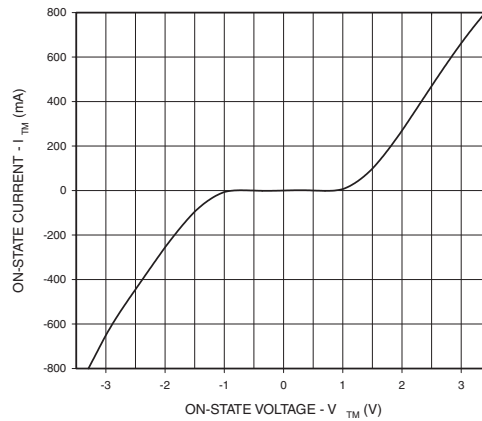

Fig. 3 Trigger Current vs. Ambient Temperature

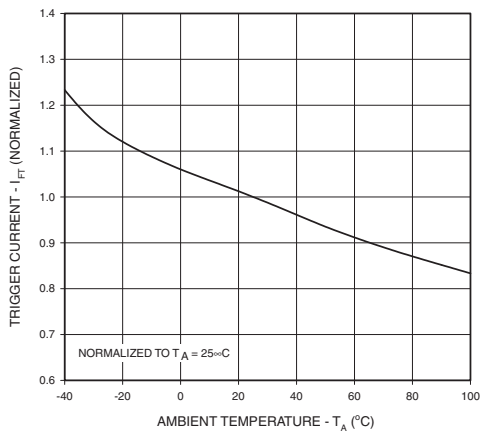

Fig. 4 LED Current Required to Trigger vs. LED Pulse Width

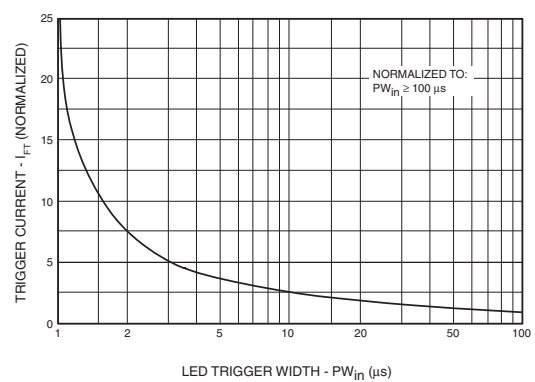

Fig. 5 dv/dt vs. Temperature

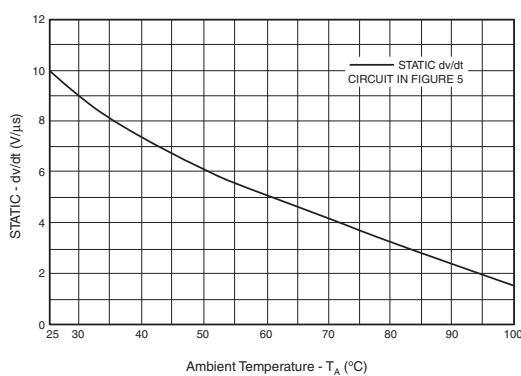
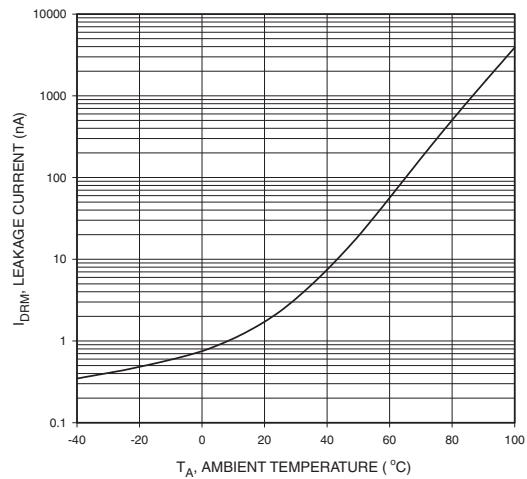
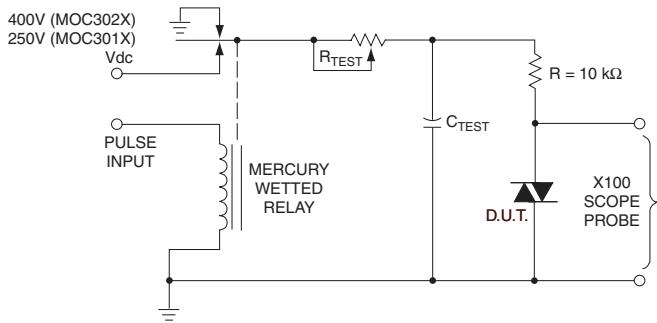

Fig. 6 Leakage Current, I_DRM vs. Temperature



MOC3010M MOC3011M MOC3012M MOC3020M MOC3021M MOC3022M MOC3023M



1. The mercury wetted relay provides a high speed repeated pulse to the D.U.T.
2. 100x scope probes are used, to allow high speeds and voltages.
3. The worst-case condition for static dv/dt is established by triggering the D.U.T. with a normal LED input current, then removing the current. The variable R_{TEST} allows the dv/dt to be gradually increased until the D.U.T. continues to trigger in response to the applied voltage pulse, even after the LED current has been removed. The dv/dt is then decreased until the D.U.T. stops triggering. τ_{RC} is measured at this point and recorded.

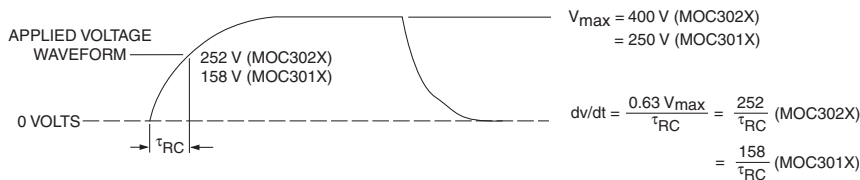

Figure 5. Static dv/dt Test Circuit

Note: This optoisolator should not be used to drive a load directly. It is intended to be a trigger device only.

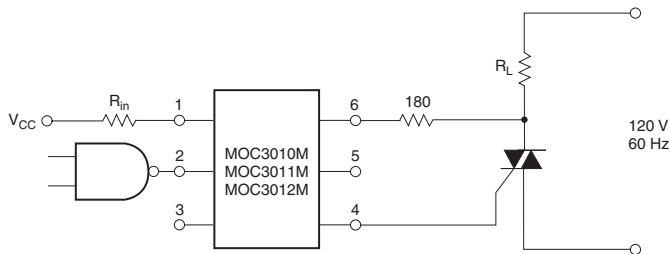

Figure 6. Resistive Load

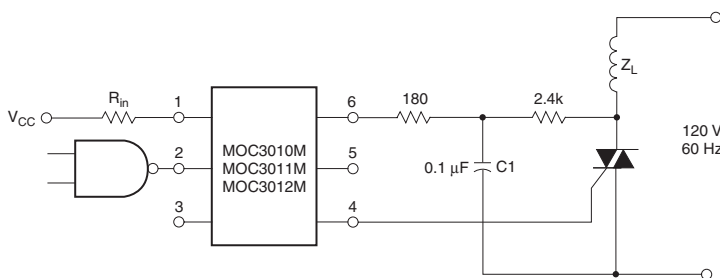

Figure 7. Inductive Load with Sensitive Gate Triac ($I_{GT} \leq 15 \text{ mA}$)

MOC3010M MOC3011M MOC3012M MOC3020M MOC3021M MOC3022M MOC3023M

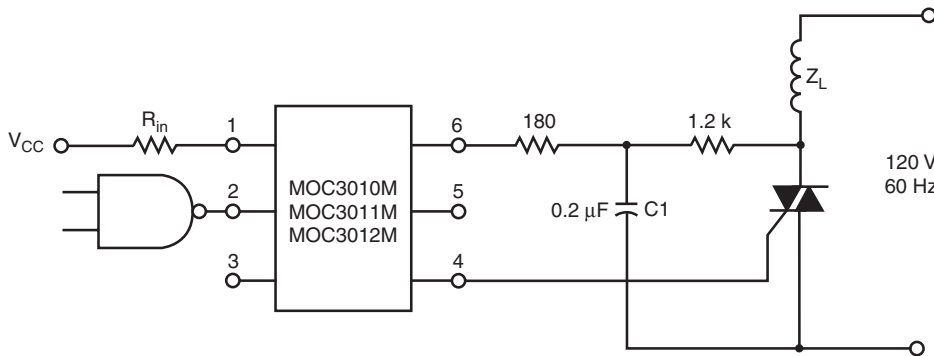
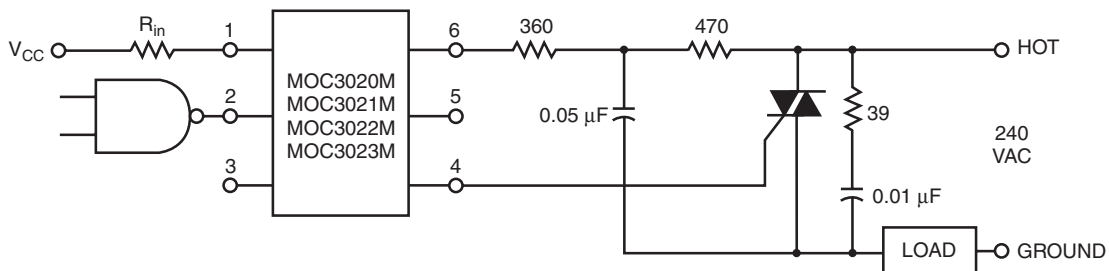

Figure 8. Inductive Load with Sensitive Gate Triac ($I_{GT} \leq 15 \text{ mA}$)



In this circuit the "hot" side of the line is switched and the load connected to the cold or ground side.

The 39 ohm resistor and 0.01 μF capacitor are for snubbing of the triac, and the 470 ohm resistor and 0.05 μF capacitor are for snubbing the coupler. These components may or may not be necessary depending upon the particular and load used.

Figure 9. Typical Application Circuit

MOC3010M MOC3011M MOC3012M MOC3020M MOC3021M MOC3022M MOC3023M

Package Dimensions (Through Hole)

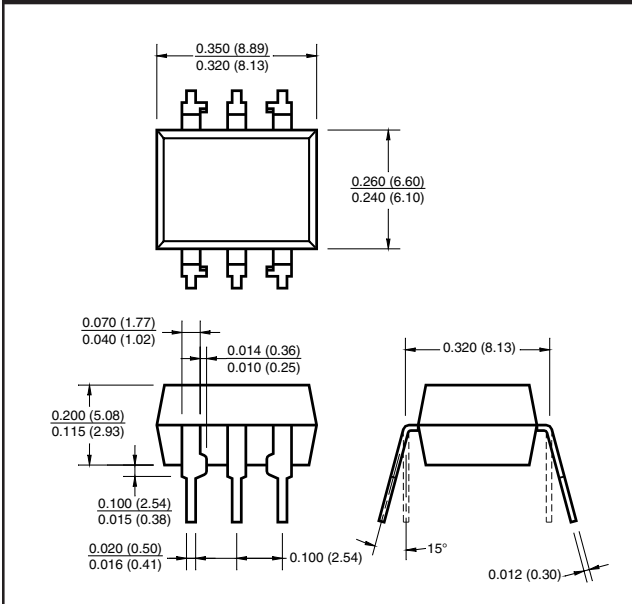

Package Dimensions (Surface Mount)

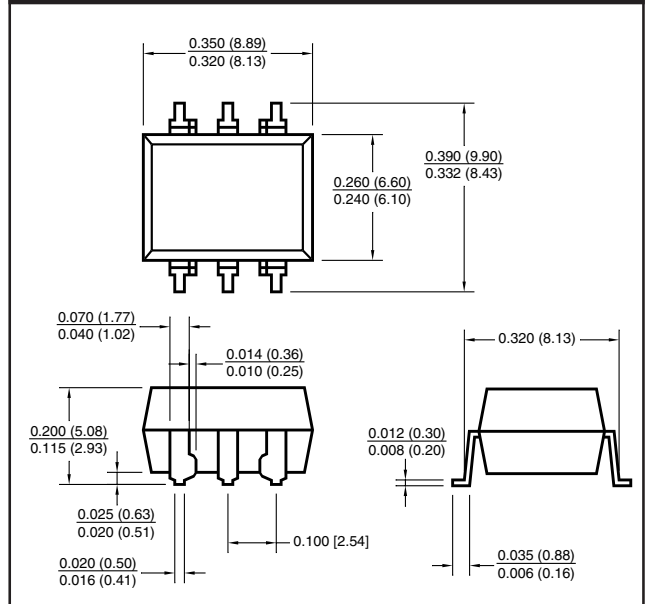

Package Dimensions (0.4" Lead Spacing)

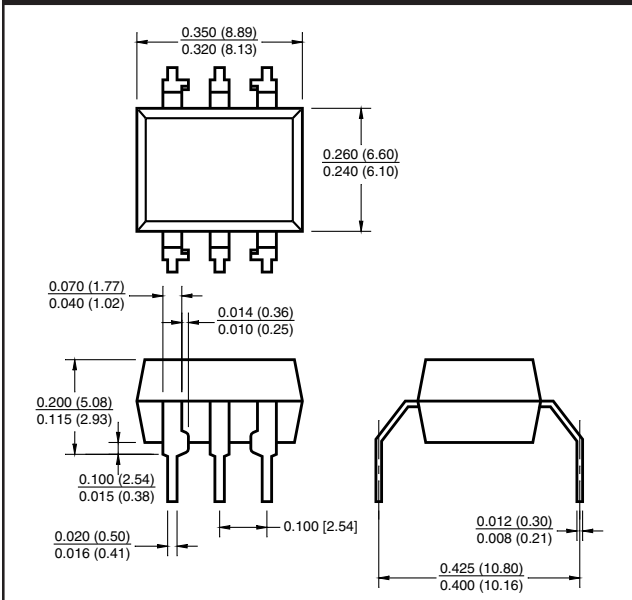

**Recommended Pad Layout for
Surface Mount Leadform**

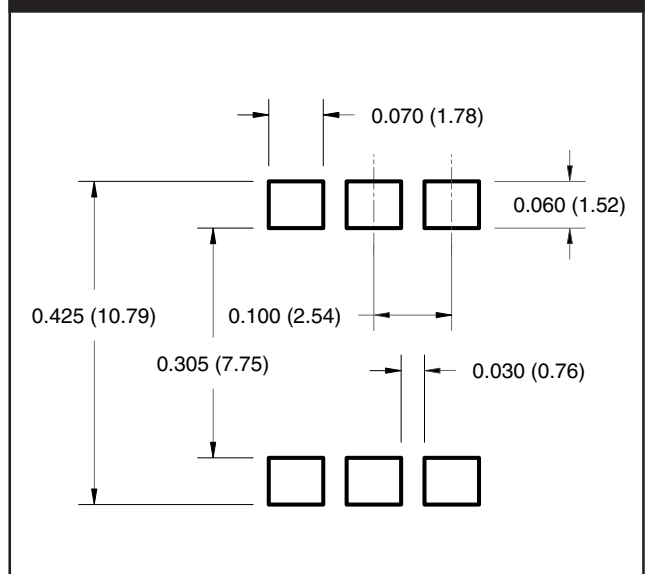

NOTE
All dimensions are in inches (millimeters)

MOC3010M MOC3011M MOC3012M MOC3020M MOC3021M MOC3022M MOC3023M

ORDERING INFORMATION

Option	Order Entry Identifier	Description
S	S	Surface Mount Lead Bend
SR2	SR2	Surface Mount; Tape and reel
T	T	0.4" Lead Spacing
V	V	VDE 0884
TV	TV	VDE 0884, 0.4" Lead Spacing
SV	SV	VDE 0884, Surface Mount
SR2V	SR2V	VDE 0884, Surface Mount, Tape & Reel

Carrier Tape Specifications

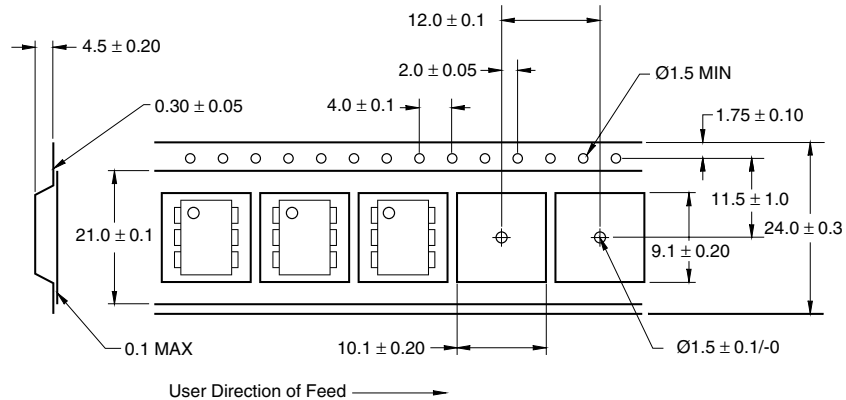

NOTE

All dimensions are in inches (millimeters)

MOC3010M MOC3011M MOC3012M MOC3020M MOC3021M MOC3022M MOC3023M

DISCLAIMER

FAIRCHILD SEMICONDUCTOR RESERVES THE RIGHT TO MAKE CHANGES WITHOUT FURTHER NOTICE TO ANY PRODUCTS HEREIN TO IMPROVE RELIABILITY, FUNCTION OR DESIGN. FAIRCHILD DOES NOT ASSUME ANY LIABILITY ARISING OUT OF THE APPLICATION OR USE OF ANY PRODUCT OR CIRCUIT DESCRIBED HEREIN; NEITHER DOES IT CONVEY ANY LICENSE UNDER ITS PATENT RIGHTS, NOR THE RIGHTS OF OTHERS.

LIFE SUPPORT POLICY

FAIRCHILD'S PRODUCTS ARE NOT AUTHORIZED FOR USE AS CRITICAL COMPONENTS IN LIFE SUPPORT DEVICES OR SYSTEMS WITHOUT THE EXPRESS WRITTEN APPROVAL OF THE PRESIDENT OF FAIRCHILD SEMICONDUCTOR CORPORATION. As used herein:

1. Life support devices or systems are devices or systems which, (a) are intended for surgical implant into the body, or (b) support or sustain life, and (c) whose failure to perform when properly used in accordance with instructions for use provided in the labeling, can be reasonably expected to result in a significant injury of the user.
2. A critical component in any component of a life support device or system whose failure to perform can be reasonably expected to cause the failure of the life support device or system, or to affect its safety or effectiveness.